

Antiquités africaines

55 | 2019

L'Afrique du Nord
de la protohistoire
à la conquête arabe

CNRS EDITIONS



55 | 2019

ANTIQUITÉS AFRICAINES

CNRS EDITIONS

ANTIQUITÉS AFRICAINES

L'AFRIQUE DU NORD DE LA PROTOHISTOIRE À LA CONQUÊTE ARABE

Les *Antiquités africaines* publient des études historiques et archéologiques intéressant l'Afrique du Nord depuis la Protohistoire jusqu'à la conquête arabe.

Fondateurs

J. LASSUS, M. LE GLAY, M. EUZENNAT, G. SOUVILLE

Directeur de publication

Cinzia VISMARA

Directeur-adjoint

Jacques GASCOU

Comité de Rédaction

Aomar AKERRAZ, Jacques ALEXANDROPOULOS, Maria Giulia AMADASI GUZZO, François BARATTE, Fathi BEJAOU, Michel BONIFAY, Véronique BROUQUIER-REDDÉ, Marie-Brigitte CARRE, Michèle COLTELLONI-TRANNOY, Ginette DI VITA-ÉVRARD, Mohamed FARAJ AL FALLOS, Toufik HAMOUM, Frédéric HURLET, David MATTINGLY, Jean-Paul RAYNAL, Jean-Christophe SOURISSEAU

Les fascicules de la revue précédant les trois dernières livraisons, ainsi que plusieurs volumes de la collection sont disponibles sur Persée, portail des revues françaises en Sciences humaines :
<http://www.persee.fr/collection/antaf>

© CNRS Éditions, Paris, 2019
15, rue Malebranche – F 75005 Paris
Tél. : 01 53 10 27 00 – Fax : 01 53 10 27 27
courriel : cnrseditions@cnrseditions.fr
site Internet : <http://www.cnrseditions.fr>

Revue Antiquités africaines
Centre Camille Jullian - MMSH
5, rue du Château de l'Horloge - B.P. 647
F – 13094 Aix-en-Provence cédex 2 (France)
tél. : 04 42 52 42 77 - fax : 04 42 52 43 75
courriel : antafr2@mms.univ-aix.fr
<http://ccj.cnrs.fr/spip.php?rubrique81>

ISBN : 978-2-271-12965-9
ISSN : 0066-4871

En application de la loi du 11 mars 1957, il est interdit de reproduire intégralement ou partiellement le présent ouvrage, sur quelque support que ce soit, sans autorisation de l'éditeur ou du Centre français d'exploitation du droit de copie, 20 rue des Grands Augustins, F – 75006 Paris.

Antiquités africaines, 55 | 2019

SOMMAIRE

<i>In memoriam</i> Noël Duval (1929-2018) par François Baratte.....	5
<i>In memoriam</i> Enrique Gozalbes Cravioto (1957-2018) par Fernando Villada	13
<i>In memoriam</i> Jihen Nacef (1973-2018) par Ridha Ghaddhab et Michel Bonifay.....	21
<i>In memoriam</i> Hédi Slim (1935-2019) par Fathi Bejaoui.....	25
Bruno D'ANDREA, Les suidés dans les pratiques alimentaires et rituelles du monde phénico-punique	29
Yamen SGHAÏER, Une tombe punique à Mellita (Îles Kerkennah - Tunisie).....	53
Sami BEN TAHAR, Le site antique de Guellala (Jerba). De la prospection à l'étude archéologique.....	71
Ali CHÉRIEF, Le <i>Fundus Tapp(hugabensis)</i> - Henchir Chaïeb. Un domaine agricole de la région de Bou Arada (Tunisie).....	97
Rubén OLMO-LÓPEZ, <i>Ad ordinandam prouinciam</i> . La misión del procónsul Galba en África	127
Moheddine CHAOUALI, Deux hommages en l'honneur de deux chevaliers en Afrique Proconsulaire. Caecilius Secundus et L. Sempronius Ianuarius	139
Amira BELHOUT, Construire dans l'Antiquité. Les outils de construction du musée de Djemila (l'antique <i>Cuicul</i>)	151
Fernando VILLADA, Darío BERNAL CASASOLA, Del istmo a las murallas reales. Un desafío para la arqueología preislámica de <i>Septem</i> (ss. I-VII d.C.).....	183
Guillaume DUPERRON, Claudio CAPELLI, Les timbres sur amphores africaines d'Arles. Une approche archéométrique.....	211
Carina HASENZAGL, Claudio CAPELLI, Petrographic characterisation of Late Roman African Pottery from J.W. Salomonson's surveys: the workshop of Sidi Khalifa.....	229

NOTES ET CHRONIQUES

Jean-Pierre DARMON, Michèle Blanchard-Lemée (1936-2017) et l'Afrique antique.....	239
---	-----

PETROGRAPHIC CHARACTERISATION OF LATE ROMAN AFRICAN POTTERY FROM J.W. SALOMONSON'S SURVEYS: THE WORKSHOP OF SIDI KHALIFA

Carina HASENZAGL*, Claudio CAPELLI**

Keywords: Tunisia, Sidi Khalifa/Pheradi Maius workshop, African Red Slip Ware, African Cooking Ware, fabric studies, petrography.

Abstract: In the frame of the study of J.W. Salomonson's survey collection of African pottery, the petrographic characterisation of selected African Red Slip Ware C/D and Cooking Ware samples from the North Tunisian production site of Sidi Khalifa is presented. Thin section analysis and binocular observations have been combined to verify the effectiveness of the latter method, to establish a coherent technological and compositional classification as well as to identify the micro- and macroscopic markers of Sidi Khalifa's production and to cross-reference them with already studied samples from consumption sites in Sicily.

Mots-clés : Tunisie, atelier de Sidi Khalifa/Pheradi Maius, sigillée africaine, culinaire africaine, études des pâtes, pétrographie.

Résumé : Nous présentons ici la caractérisation pétrographique d'échantillons sélectionnés de sigillée C/D et de culinaire récoltés sur l'atelier de Sidi Khalifa, dans le cadre de l'étude de la collection de céramique africaine de J.W. Salomonson. L'analyse pétrographique de lames minces et l'observation des pâtes à la loupe binoculaire ont été combinées dans le but de vérifier la validité de la deuxième méthode, d'établir une classification technologique et compositionnelle cohérente, d'identifier les indicateurs micro- et macroscopiques de provenance de la production de Sidi Khalifa et de les tester sur des échantillons de sites de consommation de Sicile déjà étudiés.

الكلمات المفتاح : تونس، ورشة سيدي خليفة / فبرادي ماجوس (Pheradi Maius)، السجيل الإفريقي، الفخار المعد للإستعمال اليومي، دراسة العجائن، البتروغرافيا.
تلخيص : سنقدم خلال هذا العمل الخصائص البتروغرافية للنماذج المختارة من السجيل صنف «ج» وصنف «د» ومن الفخار المعد للإستعمال اليومي، والتي تم جمعها من ورشة سيدي خليفة في إطار دراسة المجموعات الخزفية الإفريقية التي أعدها J.W. Salomonson. تم دمج طريقة التحليل البتروغرافي باعتماد الشفرات الدقيقة مع ملاحظة العجائن عبر المجهر الدقيق وذلك لعدة أسباب منها التثبت من دقة الطريقة الثانية وإعداد تصنيف تقني متطابق مع مكونات العجائن إضافة إلى تحديد المؤشرات الدقيقة والمجهريّة للفخار المتأتي من ورشة سيدي خليفة وإختبارها مع نماذج من مواقع استهلاك من سيسيليا (Sicily) تمت دراستها مسبقاً.

1. INTRODUCTION¹

The ruined city of Sidi Khalifa (ancient *Pheradi Maius*) in the Gulf of Hammamet, 13 km from the present town of Enfidah, represents the most important known production centre of African Red Slip Ware (ARS) in C/D-quality².

* Department of Archaeology, Ghent University, PhD candidate (Carina.Hasenzagl@UGent.be).

** Dipartimento di Scienze della Terra, dell'Ambiente e della Vita (DISTAV), Università degli Studi di Genova. External collaborator to the Centre Camille Jullian (Aix Marseille Univ, CNRS, CCJ, Aix-en-Provence) (capelli@dipteris.unige.it).

1. We would like to give special thanks to Michel Bonifay for kindly granting access to samples from Sidi Khalifa from previous investigations and for his valuable suggestions.

2. ARS in C/D-quality was also produced in the Central Tunisian atelier of Chougafiya and in Henchir el Ourezla recently documented by a Tunisian survey team. See BONIFAY 2004, p. 49; BEN MOUSSA 2017, p. 167-169. For the most recent overview of the traditional

The site, already explored by travellers and scientists since the 18th century, was identified as an ARS workshop in 1968 by the Dutch archaeologist J.W. Salomonson (1925-2017)³. Salomonson surveyed several Tunisian and Algerian ARS-production sites between 1961 and 1972⁴ and his archaeological activities revealed a pottery district with at least four kilns in the western and north-western portions of the ancient city. Further prospections of 1997-1999 conducted by M. Ben Moussa and S. Aounallah, who was working as site manager of *Pheradi Maius* 1998-2008, led to the discovery of numerous sherds, misfired pottery, tools and saggars as well as of kilns that were exposed because of agricultural activity and erosion⁵.

categories of ARS based on the Italian classification see: BONIFAY 2016.

3. SALOMONSON 1968, p. 95, note 38; p. 144, Appendix VII. See also HASENZAGL 2019.

4. See HASENZAGL 2019; HASENZAGL *et alii* 2019.

5. See BEN MOUSSA 2007, p. 109-131.

When Salomonson surveyed Sidi Khalifa in 1961, he collected 222 diagnostic ARS and 38 Cooking Ware fragments. Due to this large material base, it was possible to detect the characteristic spectrum of vessel types that also matches the repertoire recently documented by M. Ben Moussa⁶. Salomonson's collection includes a large diversity of ARS forms⁷ (Hayes forms 50B, 58B, 61B, 68, 79, 80B, 87A, 87A/88, 88, 91, 99, 103, 104, 105 as well as Ben Moussa's types *Pheradi Maius* 27.1, 61, 76 and 77), saggars and specimens of a limited number of Cooking Ware (Sidi Jdidi 3 and the lids Hayes 182, 195 as well as *Pheradi Maius* 93.3). The forms in Salomonson's survey material can be dated to a period spanning the 3rd to 7th centuries AD.

Unfortunately, Salomonson's collection, which also includes pottery from several other production sites, remained mainly unpublished⁸ and was stored at different European research facilities and Universities for more than half a century⁹. Since 2010 it has been studied in the interdisciplinary FACEM¹⁰ pottery project at Vienna University and in the frame of a doctoral thesis (C.H.) mainly based on the petrographic characterisation of different ARS and Cooking Ware productions by applying fabric analysis under the binocular microscope¹¹. This method focuses on the description of microscopic properties. These are defined by multiple factors: the source and treatment of clay, as well as the temperature and atmosphere during firing including the clay matrix, total percentages of voids and of temper¹² as well

6. BEN MOUSSA 2007, p. 134-215.

7. For a detailed presentation of the ARS vessel types from Salomonson's survey see: HASENZAGL 2019.

8. Apart from a study of material from the necropolis of Raqqada, and from a preliminary report of the workshops Henchir es Srira and Sidi Aïch by Marianne Stern in 1968, nothing had been published. See SALOMONSON 1968; STERN 1968. ARS from Bordj el Djerbi, Henchir el Biar, Oudna and Sidi Khalifa are presented in HASENZAGL 2019.

9. Salomonson's survey and excavation campaigns were authorised by the INAA (Institut National d'Archéologie et d'Art), and after their conclusion the collected material was first transported to the Netherlands Institute in Rome, then to Utrecht (1968), to Ghent (2003) and Vienna (2010) University. It has always been the intention to return the collection to Tunisia and Algeria. The repatriation of the material will take place after the ongoing studies are finished and in accordance with the Tunisian Antiquity Department. See also HASENZAGL *et alii* 2019.

10. FACEM (= FABrics of the CEntral Mediterranean) is an online database for specialists of Greek, Punic and Roman pottery. Its aim is to give an overview of production centres in the Central Mediterranean region by presenting images and descriptions of fabrics analyzed under the binocular microscope. For more details, see www.facem.at.

11. Carina Hasenzagl's PhD project ("Made in Africa. Production and Consumption of African Red Slip Ware in Late Antiquity") at Ghent University (promotor Prof. Roald Docter), cooperating with Vienna University (co-promoter Dr. Verena Gassner), focuses on evaluating the distribution of ARS from individual Tunisian workshops resulting in a reconstruction of the commercial relations between African producers and Mediterranean consumers at selected consumption sites. The thin sections for this project will all be analyzed by Claudio Capelli.

12. Because it is a simple method that can be also employed by archaeologists lacking geological expertise, it is not always possible to correctly denominate the individual grains, but this has

as the frequency, form and size of all sorts of inclusions and their sorting that are discernable on a fresh break¹³.

Over the past years archaeometric (chemical and petrographic) analyses based on the characterisation of kiln wasters demonstrated their importance for identifying the origin of ARS found at various consumption sites¹⁴. However, these analyses have been conducted only on selected groups and a limited number of samples, due to the high costs and also due to difficulties of gaining permission for laboratory analyses.

Alternatively, a combination of the study of ARS finds with a binocular microscope (substituted by a lens, especially on the field) utilising accessible fabric reference database, thin section data on comparable cases and a typological/macroscopic observation can often give significant results.

This paper will focus on the petrographic characterisation of Sidi Khalifa's ARS and Cooking Ware production by both the polarising and binocular microscope. Incorporating comparative data from thin section study of selected samples from Salomonson's collection and with specimens from previous investigations¹⁵, we highlight the potential of standardised fabric description under the binocular microscope to classify African pottery from individual workshops according to the characteristics discernible on a clean break¹⁶.

Building on the results of the observation with the binocular microscope of all Sidi Khalifa's samples from the Salomonson's collection, which initially led to the identification of six fabric groups¹⁷, 14 representative samples were chosen for the thin section study (tab. 1) in order to cover a wide macroscopic variability in terms of fabric, slip (or surface treatment), colour and typology. They consist of 11 ARS C/D (eight Hayes type 88, two 61B, two variants of 68, one *Pheradi Maius* 61) (fig. 1), one ARS A (?) (Hayes 27) (fig. 2), two cooking wares (Sidi Jdidi 3, Hayes 182) (fig. 2) and a sagger (fig. 2).

proven to form no obstacle in previous research. To avoid falsely labelling the inclusions, it is wise to decide against identification by name except for the easy recognisable inclusions, such as quartz or mica. Nevertheless it is obligatory to describe every kind of grain in the best possible manner with a uniform terminology. See also www.facem.at.

13. Whereas quantitative and morphological evaluations are done with comparison charts, the measurements are taken by means of the scale inside the ocular of the microscope. All reference samples are documented by digital photos with magnifications 8x, 16x, 25x and 40x.

14. E.g. MACKENSEN, SCHNEIDER 2002; BRUN 2004; MACKENSEN, SCHNEIDER 2006; CAPELLI, BONIFAY 2007; BRUN 2007; BONIFAY, CAPELLI, BRUN 2012; FOUZAI *et alii* 2012; BAKLOUTI *et alii* 2014; 2015; CAPELLI *et alii* 2016.

15. BONIFAY, CAPELLI, BRUN 2012; CAPELLI, BONIFAY 2007.

16. The description is according to the criteria applied in the online database FACEM. See www.facem.at (last consulted 14 March 2019). The surface treatment is not part of the fabric description but usually studied separately.

17. Namely groups PH-ARS-1, PH-ARS-1/2, PH-ARS-2, PH-ARS-3, PH-ARS-4 and PH-CW-1. PH = *Pheradi Maius*. All these fabrics are presented in HASENZAGL 2019. PH-CW-1 equals the older fabric code IG-ARS-3.

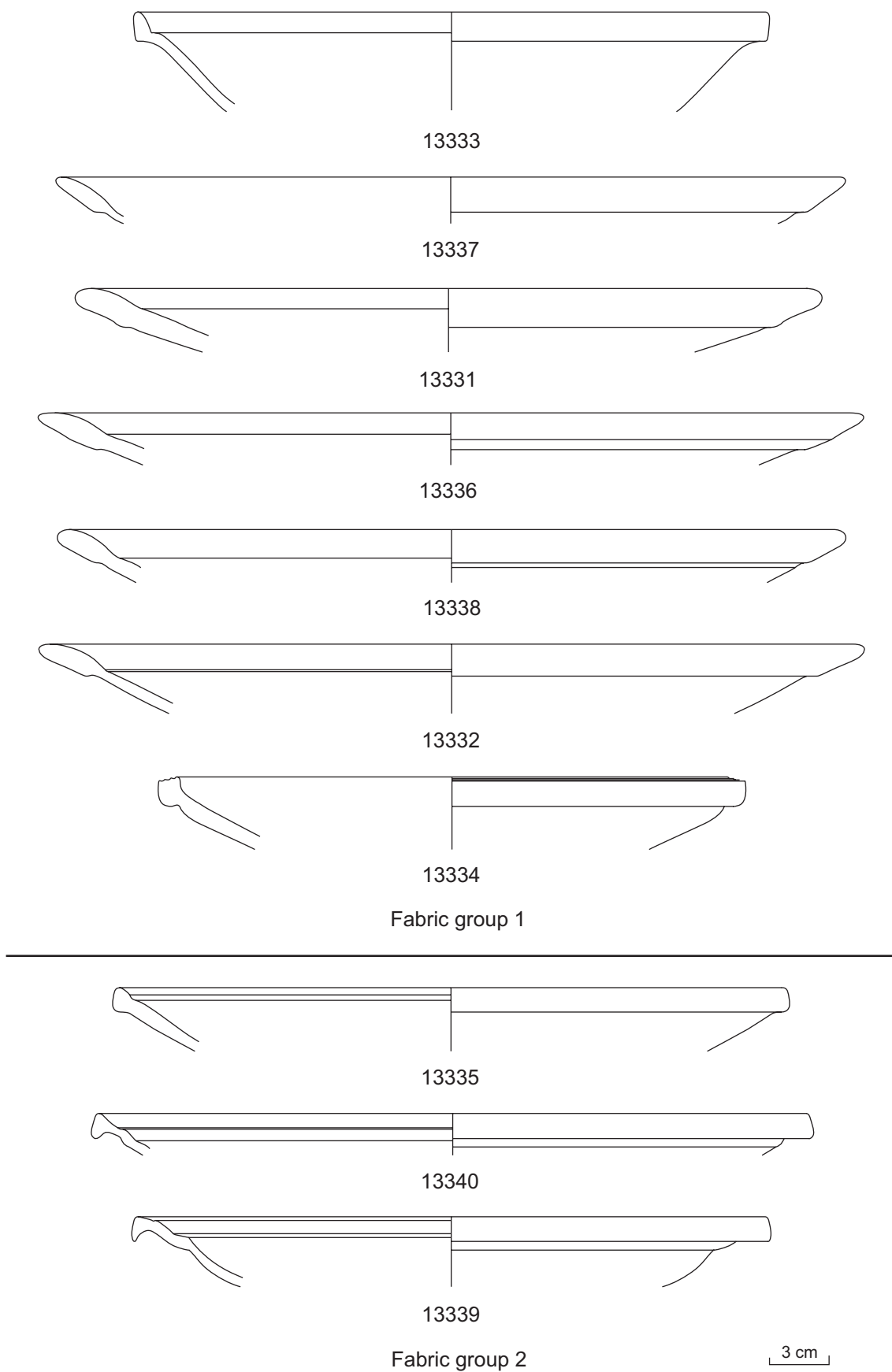

Fig. 1: Selected Sidi Khalifa ARS samples from Salomonson's survey (drawings: C. Hasenzagl).

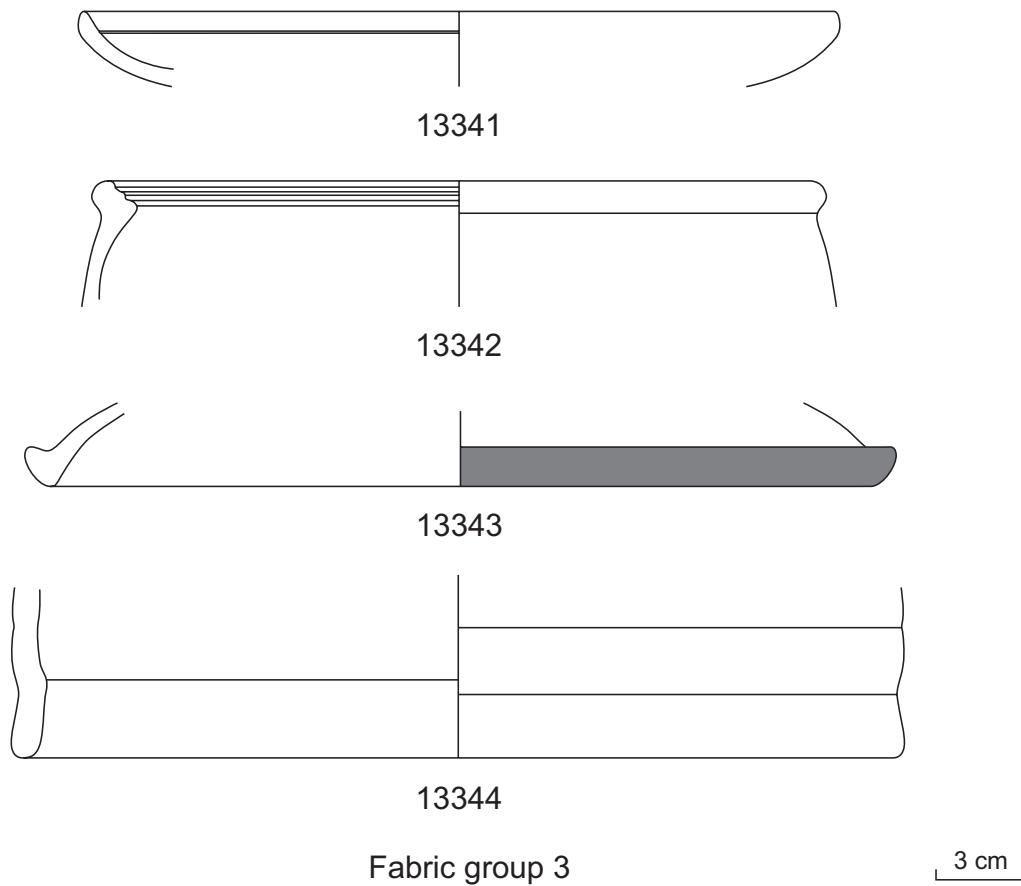

Fig. 2: Selected Cooking Ware samples from Salomonson's survey (drawings: C. Hasenzagl).

Thin section group	Binocular group (PH)	Thin section nr	Inv. (PH)	Class	Form	Max dim. (quartz, mm)	Prevailing dim. (quartz, mm)	Sorting %	Inclusions %	Rounded/aeolian quartz %	Shale %	Limonite fragments %	Quartz-sand/siltstone %	Planar (parallel) voids	Firing temperature	Slip (microns)	Slip/matrix colour
1.1	ARS-1	13333	8	ARS	HA 61B3	0.2	<0.1	+	++		+	+	-	++	++	20	>
1.1	ARS-1	13331	4	ARS	HA 88	0.2	<0.1	+	++	-	++	+		++	+++	<10	>
1.1	ARS-1	13337	180	ARS	HA 88	0.3	<0.1	+	++	-	++	+	-	+	++	10	>
1.1	ARS-3	13336	156	ARS	HA 88	0.2	<0.1	+	++		+	+		++	++	10-30	>
1.2	ARS-2	13338	201	ARS	HA 88	0.2	<0.1	++	++	+	++	+	-	+	++		
1.2	ARS-3	13332	5	ARS	HA 88	0.3	<0.1	++	++	+	++	+	+	++	+++	<10	>
1.2	ARS-1/2	13334	9	ARS	PM 61	0.3	<0.1	++	++	+	+	+		+	++		
2.1	ARS-4	13335	125	ARS	HA 61B3	0.3	<0.2	+	+++	+	+	+	+	++	+++	<10	>
2.2	ARS-4	13340	26	ARS	HA 68 var	0.4	<0.2	++ B	+++	+	+	+		+	+	10	>
2.3	ARS-4	13339	22	ARS	HA 68 var	0.5	<0.3	++ B	++	++	+	+	+	+	++		
3.1	CW-1	13341	34	ARS	HA 27	0.6	<0.5	+++ B	++	+++	+	+	-	+	++	40	>
3.1	CW-1	13342	58	ACW	MAR JD3	0.6	<0.5	+++ B	++	+++	-	+		+	++		
3.1	CW-1	13343	70	ACW	HA 182	0.7	<0.5	++ B	+++	++	+	+		++	+++		
3.2	CW-1	13344	81	SAG	saggar	0.7	<0.5	+++ B	+++	++	+	++	++	+	+++		

Tab. 1: List of the samples selected for the thin section study with their main petrographic characteristics. B: bimodal distribution.

2. THIN SECTION STUDY

Like the majority of the fabrics of ARS¹⁸ and part of the African cooking wares¹⁹, the examined samples show a Fe-rich, homogeneously oxidised (except the saggar) clay matrix and a mineralogical-petrographic composition dominated by monocrystalline quartz (fig. 3). Feldspar is very subordinate and the calcareous components are practically absent. Some of the coarser quartz grains are well rounded (with opaque surfaces visible under the stereomicroscope), which points to an aeolian origin.

Besides these generic features, Sidi Khalifa's fabrics show other more discriminant inclusions:

- fragments of Fe-rich shale (often relatively frequent), Fe-oxide/limonite and quartz-siltstone (generally scarce, not always present);
- rare fine- and medium-grained (<0.3 mm) mica (muscovite);
- (not in all the samples) small fragments of very fine-grained quartzite/chert and very rare and small zircon crystals (epidote, tourmaline, rutile, and pyroxene are also detected in very few cases).

However, a quite high textural variability, essentially in terms of sorting and dimensions of the inclusions, was observed (whereas the frequency is generally fairly high), which led us to distinguish three main fabric groups (1-3, tab. 1; fig. 3) and several (more uncertain) sub-groups, partly corresponding to typological categories.

The first two fabrics are exclusively composed of ARS C/D samples. Generally, they show a rather thin slip, which is darker (redder) than the clay matrix.

Fabric 1 (tab. 1; fig. 3) is characterised by fine-grained quartz inclusions. Two sub-groups could be distinguished in function of slight differences in the mean size and sorting degree of the inclusions.

Fabric 2 (tab. 1; fig. 3) is a little coarser than group 1. Aeolian/rounded quartz grains are present in variable (scarce) quantities. The three samples/sub-groups show a different sorting degree and frequency of both finer and coarser fractions (as well as firing temperatures). Sub-groups 2.2 and 2.3 are intermediate with group 3.

Fabric 3 (tab. 1; fig. 3) gathers samples of two African cooking ware, one saggar and one ARS A sample. They are characterised by abundant, rather well sorted quartz inclusions with bimodal distribution. They are angular in the finer fraction (<0.2 mm ca.) and often rounded in the coarser fraction (mostly 0.2-0.5 mm ca.), possibly added as temper. Shale and sandstone fragments are rare in sub-group 3.1 and relatively abundant (especially the latter) in 3.2. The saggar paste was poorly oxidised and partly vitrified, probably also because of its repeated use in the kiln.

The slip of the ARS A is slightly thicker than in ARS C/D samples of groups 1 and 2.

Considering typology, it can be observed that:

- all the five samples of Hayes 88 belong to group 1;
- the two samples of Hayes 68 belong to group 2;
- the two samples of Hayes 61B3 show different fabrics, a finer and a coarser one;
- the saggar shows the same coarse fabric as the cooking ware, which is particularly resistant to thermal shocks. That fabric is very different from the ARS C/D fabrics, especially group 1, but it is similar to the ARS A (Hayes 27) sample.

The comparative study with previously analysed reference sherds collected at Sidi Khalifa shows that:

- the fabrics (and slips) of the samples of ARS C/D²⁰ are comparable to group 1 and to subgroup 2.1;
- most of the samples of cooking ware²¹ show fabrics completely or relatively similar to group 3, but also other slightly different fabrics are present (in particular characterised by a finer grain size of the fine fraction).

Moreover, reconsidering the ARS production of Sidi Khalifa that has been recognised at consumption sites in Sicily²² (ARS D *Groupe 7*; the cooking ware samples are quite rare), and based on the integration of the petrographic and typological data, it can be said that:

- Sicily sous-groupe 7B is directly comparable to sub-group 1.1;
- sous-groupe 7A contains samples attributable to sub-group 1.2, but also specimens of another sub-group, which is distinguished by slightly coarser and better sorted inclusions and is not present in Salomonson's collection;
- almost all the samples included in a doubtful group, marginal to Groupe 7A (Marginaux), can now be attributed with certainty to Sidi Khalifa because of its correspondence with group 2;
- no fabrics directly attributable to sous-groupe 7C, which is comparable with the fabric of a few previous cooking ware reference samples, are present in Salomonson's collection.

3. BINOCULAR STUDY

Under the stereomicroscope, Sidi Khalifa's samples from Salomonson's collection are relatively homogeneous²³. All of the six groups recognised in the preliminary study (PH-ARS-1, PH-ARS-1/2, PH-ARS-2, PH-ARS-3, PH-ARS-4 and PH-CW-1, fig. 3)²⁴ are quartz/feldspar rich with varying percentages and sorting of brownish and black inclusions, argillaceous rock fragments (that is, the shale and limonitic fragments identified in thin section) and rare silver mica, as well as generally rare calcareous particles²⁵.

Whereas the nature of the inclusions and their composition is identical in all of Sidi Khalifa's fabric types, they can

20. BONIFAY, CAPELLI, BRUN 2012.

21. CAPELLI, BONIFAY 2007.

22. CAPELLI *et alii* 2016.

23. A similar homogeneity was also documented by the chemical analyses from French-Tunisian surveys by C. Brun (2007).

24. HASENZAGL 2019.

25. Carbonate pseudomorphoses, which could also derive from post-depositional processes, were not considered.

18. BONIFAY, CAPELLI, BRUN 2012.

19. CAPELLI, BONIFAY 2007.

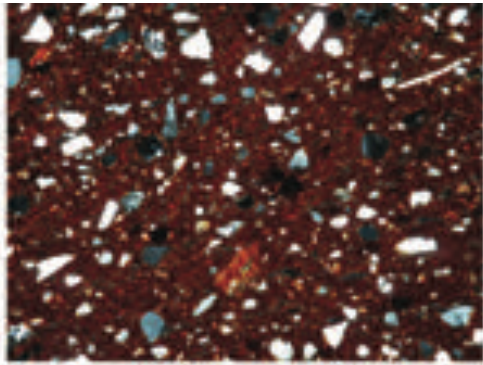

Fabric 1.1 (PH-ARS-1). Sample 13331.

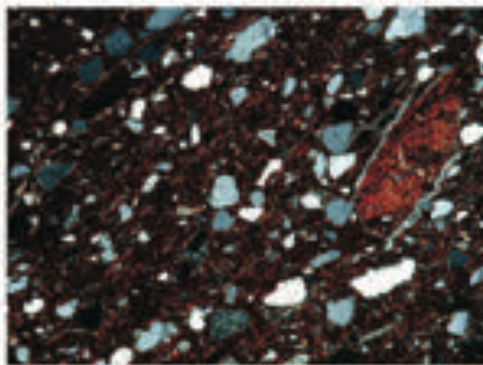
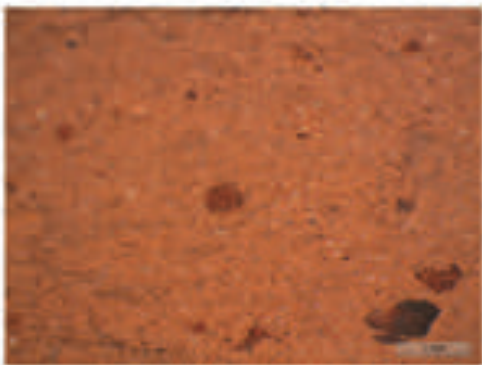

Fabric 1.2 (PH-ARS-2; PH-ARS-3). Sample 13338.

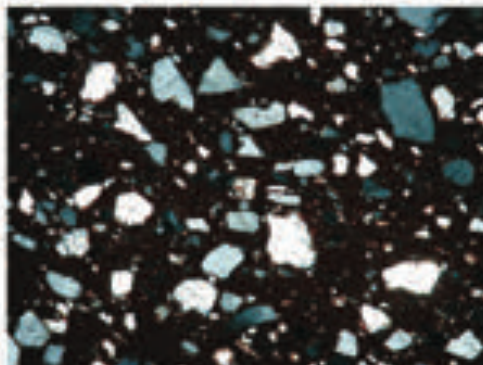
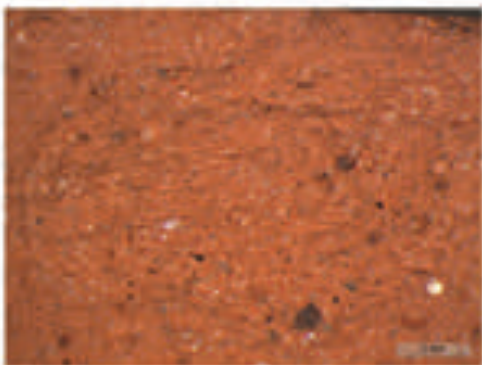

Fabric 2.1-2.3 (PH-ARS-4). Sample 13335.

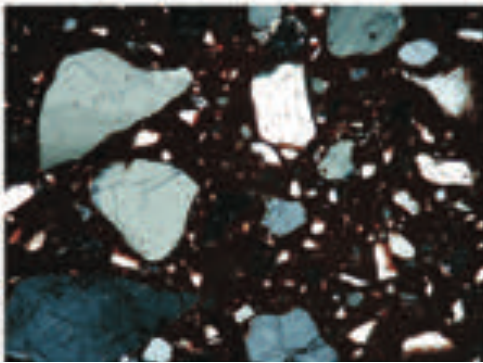
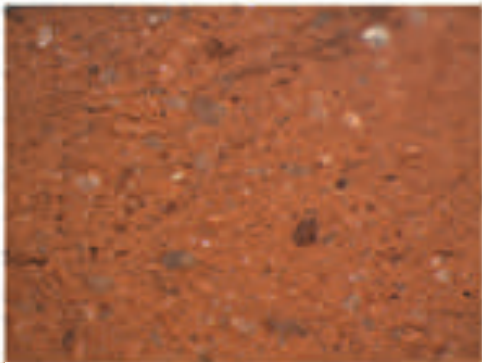

Fabric 3.1-3.2. (PH-CW-1). Sample 13342.

Fig. 3: Representative fabrics of Sidi Khalifa's ARS and Cooking Ware. Left: macrophotographs under the binocular microscope (16x, real dimensions 6.9x5.2 mm; C. Hasenzagl). Right: thin-section microphotographs (crossed Nicols, real dimensions 1.3x1 mm; C. Capelli).

only be distinguished by the number and average size of the particles creating a slightly different texture of the fresh break with the transition often being smooth. In simple terms, they can be described as fine/compact (PH-ARS-1), fine (PH-ARS-1/2), medium fine (PH-ARS-2), medium coarse (PH-ARS-3) and the coarsest (PH-ARS-4) of the ARS-series.

Taking into account the results of the thin section study presented here, former binocular groups PH-ARS-1 – PH-ARS-3 can now be included in thin section group 1 (tab.1; fig. 3) and more effectively considered as sub-groups. The fabrics show a low porosity and a moderate number of predominantly small, but also some medium-sized, inclusions. The most striking characteristic of this group are the many rust coloured to reddish-brown particles, which can reach sizes over 1 mm. In addition to the higher number of particles and voids in PH-ARS-4, it is primarily the average bigger size of the quartz/feldspar grains that makes the difference to the first group. PH-ARS-4 can be attributed to thin section group 2 (tab. 1; fig. 3).

A further increase in the dimension of the grains is visible with the Cooking Ware fabric PH-CW-1 (tab. 1; fig. 3) that equals thin section group 3 and is characterised by large, subspherical and mostly rounded quartz/feldspar particles, which are by far the most dominant inclusions and are also visible macroscopically. Furthermore, some rust-coloured and reddish-brown as well as black inclusions, mica and carbonates in low quantities can be seen. The composition and sorts of inclusions also match the fabric of the saggars.

In most cases, with some minor changes, the results of the analysis with the binocular microscope were confirmed by the thin section study. Few discrepancies still exist, which can be explained by the varying degree of precision of the binocular analysis compared to that under the polarising microscope, by textural variations in different parts of a single vessel, the very small size of the samples, the different sampling points for the two types of analysis, or by firing-related deviations or post-depositional processes that have transformed the features of the sherd.

4. CONCLUSION

On the whole, the binocular study gave satisfying results in order to document the distinguishing provenance markers of Sidi Khalifa's pottery production and to identify homogeneous groups. The integration with the thin section analysis allowed the preliminary distinctions to be verified or improved, which led in most cases to a homogeneous fabric classification.

All the samples are characterised by several discriminant compositional and technological markers, in particular by the presence in the body of shale, limonite (also visible under the binocular microscope) and rare quartz-siltstone fragments and, in the ARS C/D, by the thin dark slip and the dominant fine quartz inclusions. The cooking ware and the saggars are distinguished by the coarse, well sorted fraction.

It is important to note that a differentiation with the naked eye of Sidi Khalifa ARS fabrics (as that of other ARS productions in general) is normally not possible. Because of that, the

need to apply fabric analyses, starting by using at least a lens and for a more detailed analysis a microscope, should therefore be emphasized. In some cases, however, the microscopically coarser appearance of group 2 (PH-ARS-4) is also reflected macroscopically by a coarse and slightly porous surface. A generally coarser appearance of Sidi Khalifa's Hayes 61B was also noticed during recent studies of ARS material from Sicily²⁶. Sidi Khalifa's leading vessel types Hayes 87/88 and Hayes 88 are mainly associated with fabric group 1.

It is only possible to speculate whether the different fabrics can be interpreted as a variation of raw material or as differences in the preparation and processing of the clay by different workshops or potters.

The compositional and especially technological variability of the fabrics, however, suggests the presence of at least two different workshops/districts in the same area of Sidi Khalifa (in terms of technology as well as space and/or time): the one specialising in the production (with naturally fine or artificially levigated clays) of ARS C/D only, the other one producing cooking ware possibly together with ARS A Hayes 27 – as well as saggars for (probably) the ARS production – with quite coarse, possibly tempered fabrics.

The differentiation of the ARS-fabric groups 1 and 2, which are attributed to different vessel types dating from the 4th till the 7th century, might also be of chronological relevance. Whereas the samples of Salomonson's collection indicate that fabric 2 is more often connected to 5th-century vessel types (e.g. Hayes 61 or 68), the 6th-century forms such as Hayes 87 and Hayes 88 are almost exclusively assignable to fabric 1. The Cooking Ware fabric, however, mostly documented with 3rd century-types Sidi Jdidi 3, Hayes 182 (types B and C) as well as Hayes 195 (with black top or burnished stripes) might be linked to an earlier phase of pottery production in Sidi Khalifa. A production of Sidi Jdidi 3 at Sidi Khalifa has already been proposed in previous studies due to the large volume of wasters in Salomonson's collection²⁷. One singular fragment of Hayes 27 in fabric PH-CW-1 of A quality (slip on both sides) might be another product of an early phase. It is noteworthy that this fabric is quite different from those of the "typical" ARS A and cooking ware A and CA attributed to the Carthage area²⁸. However, the manufacturing of Hayes 27 in Sidi Khalifa remains hypothetical until further investigated.

In conclusion, the combined methodological approach of thin section analysis and standardised fabric description under the binocular microscope on Salomonson's samples not only allowed us to confirm and integrate the previous studies on Sidi Khalifa workshop, but also to get more precise results both in the identification of its pottery at the consumption sites and in the reconstruction of the organisation of the workshop area. As a less expensive and minimally destructive sampling strategy that provides easily comparable results, we argue that standardised fabric description combined with the binocular microscope can bridge the gap between conventional archaeological methods and archaeometry.

26. CAPELLI *et alii* 2016, p. 309; see also BONIFAY 2016, p. 525.

27. MUKAI 2016, p. 29; BRUN 2007, p. 570-571; BONIFAY 2004, p. 234.

28. See for example CAPELLI *et alii* 2016, *Groupe* 1.

BIBLIOGRAPHY

- BAKLOUTI S. *et alii* 2014, BAKLOUTI S., MARITAN L., LARIDHI OUAZAA N., CASAS L., JORON J.-L., LARABI KASSAA S., MOUTTE J., "Provenance and Reference Groups of African Red Slip Ware based on Statistical Analysis of Chemical Data and REE", *Journal of Archaeological Science* 50, p. 524-538.
https://www.academia.edu/13537377/Provenance_and_reference_groups_of_African_Red_Slip_ware_based_on_statistical_analysis_of_chemical_data_and_REE
- BAKLOUTI S. *et alii* 2015, BAKLOUTI S., MARITAN L., LARIDHI OUAZAA N., MAZZOLI C., LARABI KASSAA S., JORON J.-L., FOUZAI B., CASAS DUACASTELLA L., LABAYED-LAHDARI M., "African Terra Sigillata from Henchir es-Srira Archaeological Site, Central Tunisia: Archaeological Provenance and Raw Materials based on Chemical Analysis", *Applied Clay Science* 105-106, p. 27-40.
https://www.academia.edu/13537376/African_terra_sigillata_from_Henchir_Es-Srira_archaeological_site_central_Tunisia_Archaeological_provenance_and_raw_materials_based_on_chemical_analysis
- BEN MOUSSA M. 2007, *La production de sigillées africaines. Recherches d'histoire et d'archéologie en Tunisie septentrionale et centrale*, Barcelona, (Instrumenta 23).
[https://www.academia.edu/31838760/Ben_Moussa_M._La_production_de_sigill%C3%A9es_africaines._Recherches_d'histoire_et_d'archeologie_en_Tunisie_Septentrionale_et_Centrale._Instrumenta_23_\(Premi%C3%A8re_partie\)](https://www.academia.edu/31838760/Ben_Moussa_M._La_production_de_sigill%C3%A9es_africaines._Recherches_d'histoire_et_d'archeologie_en_Tunisie_Septentrionale_et_Centrale._Instrumenta_23_(Premi%C3%A8re_partie))
- BEN MOUSSA M. 2017, « Nouvelles découvertes d'ateliers de céramique antique en Tunisie », in A. MRABET (ed.), *Le peuplement du Maghreb antique et médiéval, Actes du troisième colloque international du Laboratoire de Recherche : Occupation du sol, peuplement et modes de vie dans le Maghreb antique et médiéval, Sousse, 5-7 mai 2016*, Sousse, p. 165-176.
- BONIFAY, M. 2004, *Études sur la céramique romaine tardive d'Afrique*, Oxford, (BAR Int. S., 1301).
- BONIFAY M., 2016, « Annexe 1. Éléments de typologie des céramiques de l'Afrique romaine », in *La ceramica africana* 2016, p. 507-574.
https://www.academia.edu/31392995/167_Bonifay_M._Annexe_1._El%C3%A9ments_de_typologie_des_c%C3%A9ramiques_de_l'Afrique_romaine._In_La_ceramica_africana_nella_Sicilia_romana_-_La_c%C3%A9ramique_africaine_dans_la_Sicile_romaine._Catane_IBAM_CCJ_2016_pp._507-574
- BONIFAY M., CAPELLI C., BRUN C. 2012, « Pour une approche intégrée archéologique, pétrographique et géochimique des sigillées africaines », in M. CAVALIERI, É. DE WAELE, L. MEULEMANS (eds.), *Industria Apium. L'archéologie : une démarche singulière, des pratiques multiples – Hommages à Raymond Brulet*, Louvain, p. 41-62.
https://www.academia.edu/3680174/Pour_une_approche_int%C3%A9gr%C3%A9e_arch%C3%A9ologique_p%C3%A9trographique_et_g%C3%A9ochimique_des_sigill%C3%A9es_africaines
- BRUN C. 2004, « Détermination d'origine par fluorescence X de quelques exemplaires de l'ensemble de céramiques du IV^e s. ap. J.-C. découverts dans une citerne du capitolé d'Uthina (Tunisie) », in H. BEN HASSEN, L. MAURIN (eds.), *Oudhna (Uthina), Colonie de vétérans de la XIII^e légion*. Histoire, urbanisme, fouilles et mise en valeur des monuments, Bordeaux-Paris-Tunis, (Ausonius Mémoires 13), p. 236-244.
https://www.academia.edu/3046943/D%C3%A9termination_d'origine_par_fluorescence_X_de_quelques_exemplaires_de_l'ensemble_de_c%C3%A9ramiques_du_IVe_s._ap._J.-C._d%C3%A9couverts_dans_une_citerne_du_capitol%C3%A9_d'Uthina_Tunisie
- BRUN C. 2007, « Étude technique des productions de l'atelier de Sidi Khalifa (*Pheradi Maius*, Tunisie) : céramiques culinaires, sigillées et cazettes », in *LRCW 2* 2007, p. 569-580.
https://www.academia.edu/3047098/Etude_technique_des_productions_de_l_atelier_de_Sidi_Khalifa_Pheradi_Maius_Tunisie_c%C3%A9ramiques_culinaires_sigill%C3%A9es_et_cazettes
- CAPELLI C., BONIFAY M., 2007, « Archéométrie et archéologie des céramiques africaines : une approche pluridisciplinaire », in *LRCW 2* 2007, p. 275-286.
https://www.academia.edu/5308905/CAPELLI_C._BONIFAY_M._2007_Arch%C3%A9om%C3%A9trie_et_arch%C3%A9ologie_des_c%C3%A9ramiques_africaines_une_approche_multidisciplinaire
- CAPELLI C. *et alii* 2016, CAPELLI C., BONIFAY M., FRANCO C., HUGUET C., LEITCH V. and MUKAI T., "Étude archéologique et archéométrique intégrée", in *La ceramica africana* 2016, p. 273-352.
- Ceramica africana (La)* 2016, D. MALFITANA, M. BONIFAY (dir.), *La ceramica africana nella Sicilia romana – La céramique africaine dans la Sicile romaine*, Catania, (Monografie dell'Istituto per i Beni Archeologici e Monumentali, C.N.R., 12).
- FOUZAI B. *et alii* 2012, FOUZAI B., CASAS L., OUAZAA N.L., Álvarez A., "Archaeomagnetic data from four Roman sites in Tunisia", *Journal of Archaeological Science* 39, p. 1871-1882.
https://www.academia.edu/13537375/Archaeomagnetic_data_from_four_Roman_sites_in_Tunisia
- HASENZAGL C. *et alii* 2019, HASENZAGL C., PERUGINI A., RYCKBOSCH K., DOCTER R., "The Archaeological Expeditions of Jan Willem Salomonson in Tunisia and Algeria (1960-1972)", in *De Geschiedenis van de Mediterrane Archeologie in de lege Lande*, (= *Tijdschrift voor Mediterrane Archeologie* 60), p. 54-49.
- HASENZAGL C. 2019, *North Tunisian Red Slip Ware from Production Sites in the Salomonson Survey (1960-1972)*, Leuven-Paris-Walpole MA, (*BABesch* Suppl. 37).
- LRCW 2* 2007, M. BONIFAY, J.-Ch. TRÉGLIA (eds.), *LRCW 2. Late Roman Coarse Wares, Cooking Wares and Amphorae in the Mediterranean: Archaeology and Archaeometry*, Oxford, (BAR Int. S. 1662)
- MACKENSEN M., SCHNEIDER G. 2002, "Production Centers of African Red Slip Ware (3rd-7th c.) in Northern and Central Tunisia: Archaeological Provenance and Reference Groups Based on Chemical Analysis", *JRA* 15, p. 121-158.
- MACKENSEN M., SCHNEIDER G. 2006, "Production Centers of African Red Slip Ware (2nd-3rd c.) in Northern and Central Tunisia: Archaeological Provenance and Reference Groups based on Chemical Analysis", *JRA* 19, p. 163-190.
- MUKAI T. 2016, *La céramique du groupe épiscopal d'Aradi / Sidi Jdidi (Tunisie)*, Oxford, (Roman and Late Antique Mediterranean Pottery 9)
- SALOMONSON J.W. 1968, « Études sur la céramique romaine d'Afrique. Sigillée claire et céramique commune de Henchir el Ouiba (Raqqada) en Tunisie centrale », *BABesch* 43, p. 80-145.
- STERN E.M. 1968, « Note analytique sur des tessons de sigillée claire ramassés à Henchir es Srira et Sidi Aïch », *BABesch* 43, p. 146-154.

ANTIQUITÉS AFRICAINES

NOTE AUX AUTEURS CONCERNANT LA PRÉSENTATION DES MANUSCRITS

Les manuscrits doivent être envoyés à la Rédaction (adresse ci-dessous) au format numérique avant le **30 novembre**. Les articles, saisis ou composés sous Word, seront enregistrés dans un fichier au format RTF, formaté comme suit : corps du document en style standard, police de caractères Times 12 pts, double interligne, sans césures manuelles des mots ; notes de bas de page insérées et numérotées automatiquement (Menu : Insertion, Note de bas de page), police de caractères Times 10 pts, interligne simple.

L'auteur joindra à son article un résumé (10 lignes maximum) ainsi que des mots-clefs (précisant la localisation géographique : pays, province romaine ; ville, le thème ; la datation...) en français, dans la langue de l'article si celle-ci est autre, ainsi qu'en arabe. Pour les auteurs non arabophones, la traduction sera assurée par la rédaction.

Dans le cas où des caractères spéciaux sont utilisés (textes comportant du grec, du libyque, de l'arabe), il est indispensable de fournir les polices employées et d'indiquer clairement sur l'épreuve papier la présence de chacun de ces caractères. Les polices de caractères seront au format TrueType (fichier TTF), OpenType (fichier OTF) ou Postscript (fichier PFM).

NOTES BIBLIOGRAPHIQUES

Abrégées, elles doivent être présentées de la façon suivante : le nom de l'auteur en PETITES MAJUSCULES, la date de publication et, éventuellement, le(s) numéro(s) de la(des) page(s), de la(des) figure(s) et planche(s) (ex : LE GLAY 1961, p. 219, fig. 6, pl. XIX).

BIBLIOGRAPHIE

Elle est regroupée par ordre alphabétique, puis chronologique, des auteurs, en fin de manuscrit.

Pour un volume : LE GLAY M. 1961, *Saturne africain. Monuments*, I, Paris.

Pour un article : LASSUS J. 1971, « La salle à sept absides de Djemila-Cuicul », *AntAfr* 5, p. 193-207.

Les normes bibliographiques sont consultables en ligne à l'adresse : <http://ccj.cnrs.fr/spip.php?article781>

ILLUSTRATIONS

Toutes les illustrations seront fournies libres de droits pour l'édition papier et pour l'édition en ligne. Lorsqu'un détournement est nécessaire, il sera effectué par l'auteur.

Les figures au trait seront fournies sur calque ou numériques (préciser les formats et logiciels employés). Lorsque celles-ci comportent du texte, la (ou les) police(s) de caractères utilisée(s) devront être incluses (cocher l'option « Inclure les polices dans le document » lors de l'enregistrement du fichier).

La liste des légendes sera regroupée sur fichier séparé et mentionnera précisément la provenance ou l'auteur de l'illustration.

Les fichiers sources des illustrations (photographies, cartes et schémas) seront enregistrés dans l'un des formats suivants : .tif, .png, .bmp, .eps, .svg, .ai ou .psd, à une taille et à une résolution suffisantes pour une utilisation sans agrandissement et pour l'impression, à savoir :

- 300 ppp ou dpi minimum pour les images en couleurs ;
- 600 ppp ou dpi minimum pour les images en niveaux de gris ;
- 1 200 ppp ou dpi pour les reproductions au trait.

Sont absolument à proscrire : les illustrations et graphiques directement insérés dans un document Word ; les illustrations en basse résolution (inférieur à 300 ppp ou dpi) ; les formats de compression destructrice (notamment, les images au format .jpg).

L'auteur mentionnera son nom, l'adresse et l'organisme scientifique auquel il est rattaché, ainsi que son adresse mail officielle, en tête des notes. Il indiquera également la date qu'il souhaite voir figurer au bas de son article. Dans son envoi, il précisera son adresse courriel à laquelle pourront lui parvenir les épreuves et son adresse postale. Par ailleurs, l'auteur s'engagera à ne pas publier son article dans un autre ouvrage (revue ou volume collectif).

Trois ans après la parution, la revue est disponible en ligne sur le portail des revues françaises en SHS, Persée. Pour cela, les auteurs doivent s'assurer de posséder les autorisations nécessaires pour toutes leurs illustrations. Après acceptation de l'article par le Comité de lecture, la rédaction demandera à l'auteur de signer une autorisation de mise en ligne, valable aussi pour les illustrations.

REVUE ANTIQUITÉS AFRICAINES
Centre Camille Jullian - M.M.S.H.
5, rue du Château de l'Horloge - B.P. 647
13094 Aix-en-Provence Cedex 2
tél.: 04 42 52 42 77 - fax: 04 42 52 43 75
courriel : antafr2@mmsch.univ-aix.fr

ANTIQUITÉS AFRICAINES

ISBN 2-222-01014-4	Tome 1 - 1967	
ISBN 2-222-01068-3	Tome 2 - 1968	
ISBN 2-222-01184-3	Tome 3 - 1969	
ISBN 2-222-01267-8	Tome 4 - 1970	
ISBN 2-222-01360-7	Tome 5 - 1971	
ISBN 2-222-01441-7	Tome 6 - 1972	
ISBN 2-222-01576-6	Tome 7 - 1973	
ISBN 2-222-01689-4	Tome 8 - 1974	
ISBN 2-222-01793-9	Tome 9 - 1975	
ISBN 2-222-01698-3	Tome 10 - 1976	
ISBN 2-222-02083-2	Tome 11 - 1977	
ISBN 2-222-02211-8	Tome 12 - 1978	
ISBN 2-222-02306-8	Tome 13 - 1979	
ISBN 2-222-02357-2	Tome 14 - 1979,	Hommages à Jean Lassus, 1
ISBN 2-222-02610-5	Tome 15 - 1980,	Hommages à Jean Lassus, 2
ISBN 2-222-02645-8	Tome 16 - 1980,	Hommages à Jean Lassus, 3
ISBN 2-222-02853-1	Tome 17 - 1981	
ISBN 2-222-03075-7	Tome 18 - 1982	
ISBN 2-222-03291-1	Tome 19 - 1983	
ISBN 2-222-03422-1	Tome 20 - 1984	
ISBN 2-222-03590-2	Tome 21 - 1985	
ISBN 2-222-03697-6	Tome 22 - 1986	
ISBN 2-222-03894-4	Tome 23 - 1987	
ISBN 2-222-04084-1	Tome 24 - 1988	
ISBN 2-222-04231-3	Tome 25 - 1989	
ISBN 2-222-04435-9	Tome 26 - 1990	
ISBN 2-222-04573-8	Tome 27 - 1991	
ISBN 2-222-04718-8	Tome 28 - 1992	
ISBN 2-271-05041-3	Tome 29 - 1993	
ISBN 2-271-05160-6	Tome 30 - 1994	
ISBN 2-271-05359-5	Tome 31 - 1995	
ISBN 2-271-05431-1	Tome 32 - 1996	
ISBN 2-271-05508-3	Tome 33 - 1997,	Hommages à Georges Souville, 1
ISBN 2-271-05579-2	Tome 34 - 1998,	Hommages à Georges Souville, 2
ISBN 2-271-05676-4	Tome 35 - 1999	
ISBN 2-271-05777-9	Tome 36 - 2000	
ISBN 2-271-06061-3	Tome 37 - 2001,	Peuplement et mouvements de population en Afrique du Nord antique et médiévale
ISBN 2-271-06151-2	Tome 38-39 - 2002-2003	
ISBN 2-271-06342-7	Tome 40-41 - 2004-2005	
ISBN 2-271-06526-1	Tome 42 - 2006	
ISBN 2-271-06700-5	Tome 43 - 2007	
ISBN 2-271-06947-4	Tome 44 - 2008	
ISBN 978-2-271-07157-6	Tome 45 - 2009	
ISBN 978-2-271-07137-6	Tome 46-48 - 2010-2012	
ISBN 978-2-271-07974-9	Tome 49 - 2013	
ISBN 978-2-271-08263-3	Tome 50 - 2014	
ISBN 978-2-271-08833-8	Tome 51 - 2015	
ISBN 978-2-271-09352-3	Tome 52 - 2016	
ISBN 978-2-271-11767-0	Tome 53 - 2017	
ISBN 978-2-271-12262-9	Tome 54 - 2018	

Pour tout achat de la revue *Antiquités africaines* ou de la collection Études d'Antiquités africaines,
s'adresser à CNRS Éditions : <http://www.cnrseditions.fr/>

ÉTUDES D'ANTIQUITÉS AFRICAINES

- Inscriptions antiques du Maroc, I. Inscriptions libyques, par L. GALAND. Inscriptions puniques et néopuniques, par J. FÉVRIER.
Inscriptions hébraïques des sites antiques, par G. VAJDA, 1966.
- Palais et demeures de Tunis, XVI^e et XVII^e siècles, par J. REVAULT, 1967 (réimpression 1980).
- Carthage-Utique. Études d'architecture et d'urbanisme, par A. LÉZINE, 1968.
- Lampes de Carthage, par J. DENEAUVE, 1969 (réimpression 1975).
- Les mosaïques de Timgad. Étude descriptive et analytique, par S. GERMAIN, 1969 (réimpression 1973).
- Palais et demeures de Tunis, XVIII^e et XIX^e siècles, par J. REVAULT, 1971 (réimpression 1983).
- Atlas préhistorique du Maroc, 1. Le Maroc atlantique, par G. SOUVILLE, 1973.
- Recherches sur le *Limes Tripolitanus*, par P. TROUSSET, 1974.
- Palais et résidences d'été de la région de Tunis, par J. REVAULT, 1974.
- Maisons à mosaïques du quartier central de Djemila (*Cuicul*), par M. BLANCHARD-LEMÉE, 1975.
- Un gisement capsien de faciès sétifien, Medjez II El-Eulma (Algérie), par H. CAMPS-FABRER, 1975.
- Saint Cyprien, évêque de Carthage, «pape» d'Afrique (248-258). Contribution à l'étude des «persécutions» de Dèce et de Valérien, par Ch. SAUMAGNE, 1975.
- Lampes chrétiennes de Tunisie (musées du Bardo et de Carthage), par A. ENNABLI, 1976.
- Vbique Populus*, peuplement et mouvements de population dans l'Afrique romaine de la chute de Carthage à la fin de la dynastie des Sévères (146 av. J.-C. – 235 ap. J.-C.) par J.-M. LASSÈRE, 1977.
- L'habitation tunisoise. Pierre, marbre et fer dans la construction et le décor, par J. REVAULT, 1978.
- Économie pastorale pré-agricole en Algérie orientale. Le Néolithique de tradition capsienne, l'exemple de l'Aurès, par C. ROUBET, 1979.
- Le temple B de *Volubilis*, par H. MORESTIN, 1980.
- La forteresse byzantine de *Thamugadi*, 1. Fouilles à Timgad 1938-1956, par J. LASSUS, 1981.
- Inscriptions antiques du Maroc, 2. Inscriptions latines, par M. EUZENNAT, J. MARION et J. GASCOU, 1982.
- Prosopographie chrétienne du Bas-Empire, 1. Prosopographie de l'Afrique chrétienne (303-533), par A. MANDOUZE, 1982.
- Les tombes puniques de Carthage, par H. BENICHOUSAFAR, 1982.
- Index onomastique des inscriptions latines de la Tunisie, par Z. BEN ABDALLAH et L. LADJIMI SEBAÏ, 1983.
- La nécropole orientale de *Sitifis* (Sétif, Algérie). Fouilles de 1966-1967, par R. GUÉRY, 1985.
- Le Bas-Sahara dans la Préhistoire, par G. AUMASSIP, 1986.
- Cyrène et la Libye hellénistique – *Libykai Historiai* – de l'époque républicaine au principat d'Auguste, par A. LARONDE, 1987.
- Synésios de Cyrène et la Cyrénaïque du Bas-Empire, par D. ROQUES, 1987.
- La Troisième légion Auguste, par Y. Le BOHEC, 1989.
- Le *limes* de Tingitane, la frontière méridionale, par M. EUZENNAT, 1989.
- Les unités auxiliaires de l'armée romaine en Afrique proconsulaire et Numidie sous le Haut-Empire, par Y. Le BOHEC, 1989.
- Le Tell nord-est tunisien dans l'Antiquité. Essai de monographie régionale, par J. PEYRAS, 1991.
- Temples et cultes de Tripolitaine, par V. BROUQUIER-REDDÉ, 1992.
- Carthage, une métropole chrétienne du IV^e à la fin du VII^e siècle, par L. ENNABLI, 1997.
- Le royaume de Maurétanie sous Juba II et Ptolémée, par M. COLTELLONI-TRANNOY, 1997.
- La basilique de Carthagenna et le locus des sept moines de Gafsa. Nouveaux édifices chrétiens de Carthage, par L. ENNABLI, 2000.
- Le trésor de Carthage : contribution à l'étude de l'orfèvrerie de l'Antiquité tardive, par F. BARATTE, J. LANG, C. METZGER et S. La NIECE, 2002.
- Inscriptions antiques du Maroc, 2. Inscriptions latines - Supplément, par N. LABORY, 2003.
- Le littoral de la Tunisie. Étude géoarchéologique et historique, par H. SLIM, P. TROUSSET, R. PASKOFF et A. OUESLATI, avec la collaboration de M. Bonifay et J. Lenne, 2004.
- Corpus des mosaïques de Cherchel, par S. FERDI, 2005.
- Lieux de cultes : aires votives, temples, églises, mosquées. IX^e Colloque international sur l'histoire et l'archéologie de l'Afrique du Nord antique et médiévale (Tripoli, 19-25 février 2005), 2008.
- Maisons de *Clupea*. Exemples de l'architecture domestique dans un port de l'Afrique proconsulaire. Les maisons de l'École de pêche, par J.-M. LASSÈRE et H. SLIM, avec une étude de la céramique par J. Piton, 2010.
- Africa, quasi Roma* (256 av. J.-C. – 711 apr. J.-C.), par J.-M. LASSÈRE, 2015.
- L'édifice appelé « maison de Bacchus » à Djémila, par P.-A. FÉVRIER†, M. BLANCHARD-LEMÉE, Fr. BARATTE, P. PENSABENE et H. KAHWAGI-JANHO, 2019.
- Carthage, « des travaux et des jours », par A. ENNABLI (en préparation).

Antiquités africaines

Table des matières 55 | 2019

<i>In memoriam</i> Noël DUVAL (1929-2018) par François BARATTE.....	5
<i>In memoriam</i> Enrique GOZALBES CRAVIOTO (1957-2018) par Fernando VILLADA	13
<i>In memoriam</i> Jihen NACEF (1973-2018) par Ridha GHADDHAB et Michel BONIFAY	21
<i>In memoriam</i> Hédi SLIM (1935-2019) par Fathi BEJAOUI	25
Bruno D'ANDREA, Les suidés dans les pratiques alimentaires et rituelles du monde phénico-punique	29
Yamen SGHAÏER, Une tombe punique à Mellita (Îles Kerkennah - Tunisie)	53
Sami BEN TAHAR, Le site antique de Guellala (Jerba). De la prospection à l'étude archéologique	71
Ali CHÉRIF, Le <i>Fundus Tapp(bugabensis)</i> - Henchir Chaïeb. Un domaine agricole de la région de Bou Arada (Tunisie).....	97
Rubén OLMO-LÓPEZ, <i>Ad ordinandam prouinciam</i> . La misión del procónsul Galba en África.....	127
Moheddine CHAOUALI, Deux hommages en l'honneur de deux chevaliers en Afrique Proconsulaire. Caecilius Secundus et L. Sempronius Ianuarius	139
Amira BELHOUT, Construire dans l'Antiquité. Les outils de construction du musée de Djemila (l'antique <i>Cuicul</i>)	151
Fernando VILLADA, Darío BERNAL CASASOLA, Del istmo a las murallas reales. Un desafío para la arqueología preislámica de <i>Septem</i> (ss. I-VII d.C.)	183
Guillaume DUPERRON, Claudio CAPELLI, Les timbres sur amphores africaines d'Arles. Une approche archéométrique	211
Carina HASENZAGL, Claudio CAPELLI, Petrographic characterisation of Late Roman African Pottery from J.W. Salomonson's surveys: the workshop of Sidi Khalifa	229

NOTES ET CHRONIQUES

Jean-Pierre DARMON, Michèle Blanchard-Lemée (1936-2017) et l'Afrique antique.....	239
---	-----

50 € prix valable en France

ISSN : 0066-4871

ISBN : 978-2-271-12965-9



www.cnrseditions.fr

Djemila, Algérie. Temple septimien.
Cliché CNRS/G. Réveillac -
Centre Camille Jullian et Recherches
d'Antiquités africaines.